

# WIEGAND

## Reader Input & Output Interface Basic Set

### Features for BASIC Set:

#### Reader Data Only

- ▶ Provides a cost effective solution for upgrading and replacing existing coax based systems with any Wiegand Protocol.
- ▶ Provides power for 12V or 5V card reader.
- ▶ Consists of two simple to install modules:
  - ▷ A control unit module (UW2CC-1 Basic)
  - ▷ A door module (UW2CC-2 Basic)
- ▶ Works with coax distances up to 1000 feet.
- ▶ Improves wire manageability on large scale installations simplifying both wire installation and wire identification.
- ▶ Fast and easy, hassle-free installation.



#### Module functions

The operation of LED may be control by the host panel. The LED may then exhibit a red or green color for certain status conditions as controlled by the host panel software.

#### **LED And REV Connection Functions for UW2CC-1 Basic And Standard Modules:**

In order to have the module # 1 LED in correct state (red) during card reader normal state, the LED connection from the host panel/software shall be Negative (Low 0.0 volts). If host panel LED connection is Positive (High +5.0 volts), the host Panel LED terminal shall be connected to the terminal marked REV on the UW2CC-1 module.

#### **LED And REV Connection Functions For UW2CC-2 Basic And Standard Modules:**

Module # 2 provides two connection possibilities for card reader LED operation.

1.The LED terminal connection provides Negative (Low 0.0 volts) while the card reader is in normal state. The LED Module terminal Positive (High +5.0 volts) while the card reader is in an active state.

2.The REV terminal connection provides Positive (High +5.0 volts) while the card reader is in normal state. REV terminal Negative (Low 0.0 volts) while the card reader is in an active state.

#### Specifications:

<b>Power Requirements:</b>	18-24V 500mA
<b>Dimensions:</b>	4.9in. x 2.12in. x 0.9in. (Each)
<b>Wiring Distances</b>	Module (UW2CC-1) to Module (UW2CC-2) coaxial cable: Up to 1000 Feet. Module (UW2CC-2) to card reader, 18 AWG. 6 con. Shielded jacketed cable: Up to 500 Feet.
<b>Tolerances:</b>	<b>Temperature:</b> -10°F to 130°F (-23°C to 55°C) <b>Relative Humidity:</b> 0 to 100% Non-Condensing

\_\_\_\_\_ Limited Product Warranty For A Period of Two Years \_\_\_\_\_  
Ascom Systems warrants modules to be free from defects in materials and workmanship for two years form date of purchase.



P.O. Box 651271 Miami, FL 33165-1271  
305.266.7737 ascomsys@ascomsystems.com

Se habla Español  
www.ascomsystems.com

# Wiring Diagram for BASIC Set, Modules: UW2CC-1

### Connections: Module UW2CC-1 ( BASIC)

Terminal	UW2CC-1 Module Description
Gn-0	Data "0"
Wh-1	Data "1"
LED	Low (see module #1 function )
REV	High (See module #1 function)
GND	Ground connection

### Notes:

- \* 1. Red (Power) LED will not activate if a card reader is not connected. Card reader power supplied by UW1CC-1.
- 2. Includes circuit protection against reverse polarity and short circuit in coaxial cable. All circuits will return to normal once short is cleared.

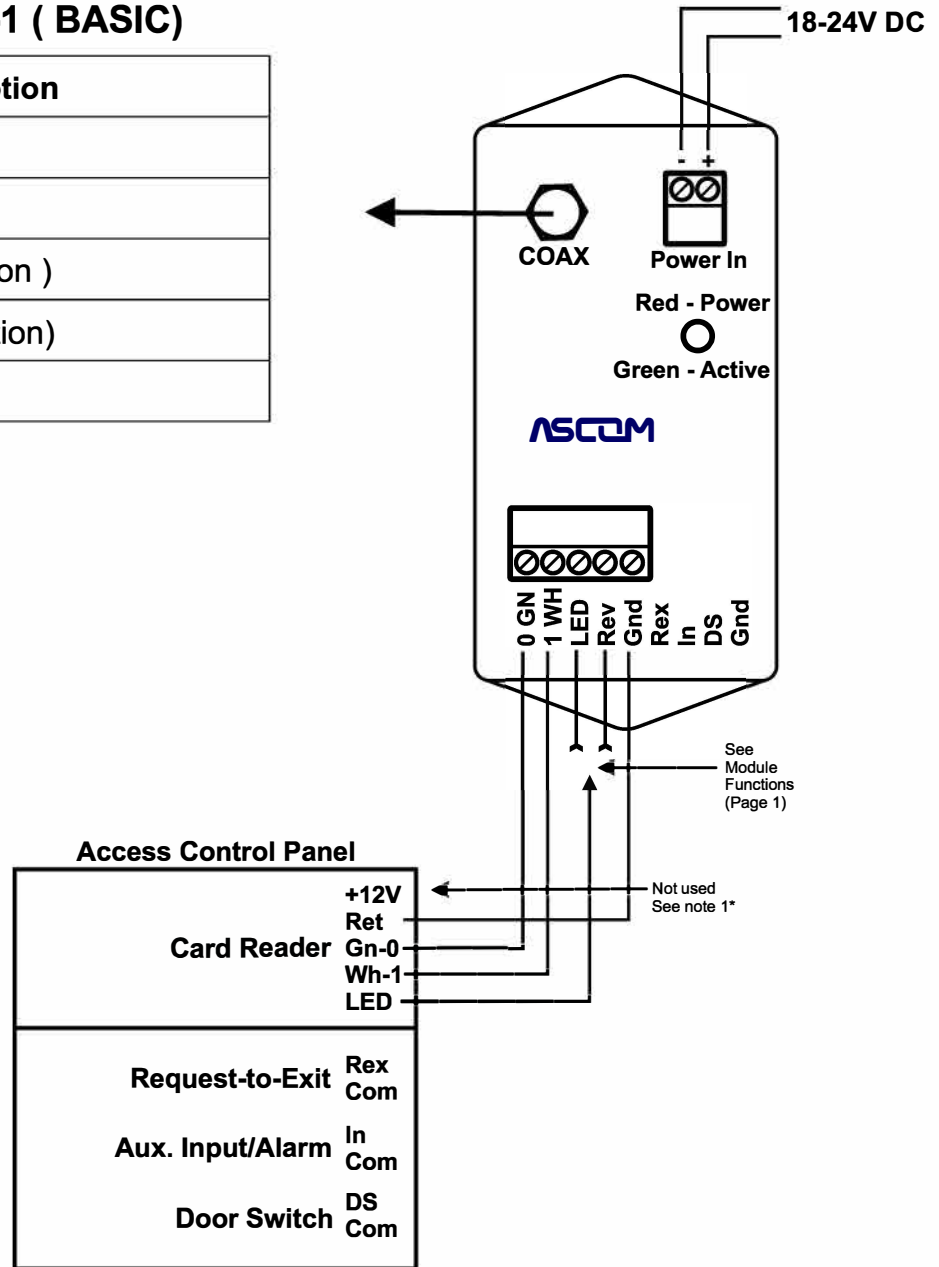

Limited Product Warranty For A Period of Two Years  
 Ascom Systems warrants modules to be free from defects in materials and workmanship for two years form date of purchase.

# Wiring Diagram for BASIC Set, Modules: UW2CC-2

## Connections: Module UW2CC-2 ( BASIC)

Terminal	UW2CC-2 Module Description
+12V	12 Volts Card Reader Power
Ret	Power Return
Gn-0	Data "0"
Wh-1	Data "1"
+5V	5 Volts Card Reader Power
REV	High (See module #2 function)
LED	Low (see module #2 function )

**\*Important:** Incorrect connection may result in overloading modules. Please refer to host access control panel.

### Notes:

1. 250mA MAX.
2. Includes circuit protection against reverse polarity and short circuit in coaxial cable. All circuits will return to normal once short is cleared.

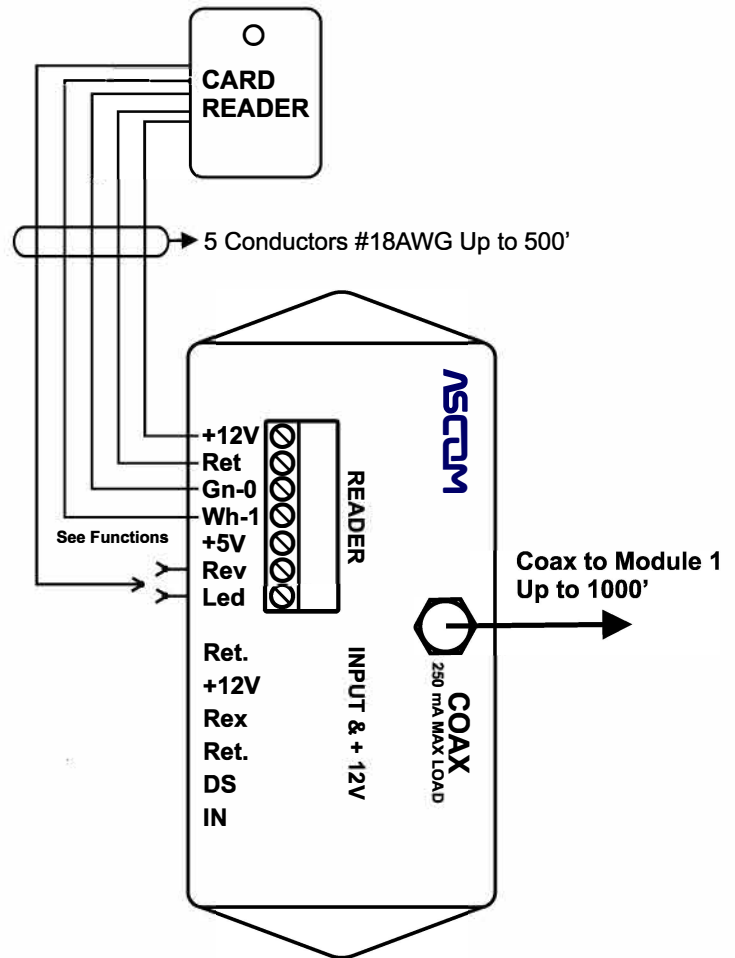

Limited Product Warranty For A Period of Two Years  
Ascom Systems warrants modules to be free from defects in materials and workmanship for two years from date of purchase.